

SCHMATIC DIAGRAM OF TWIN RUDDER
WITH CONNECTION ROD

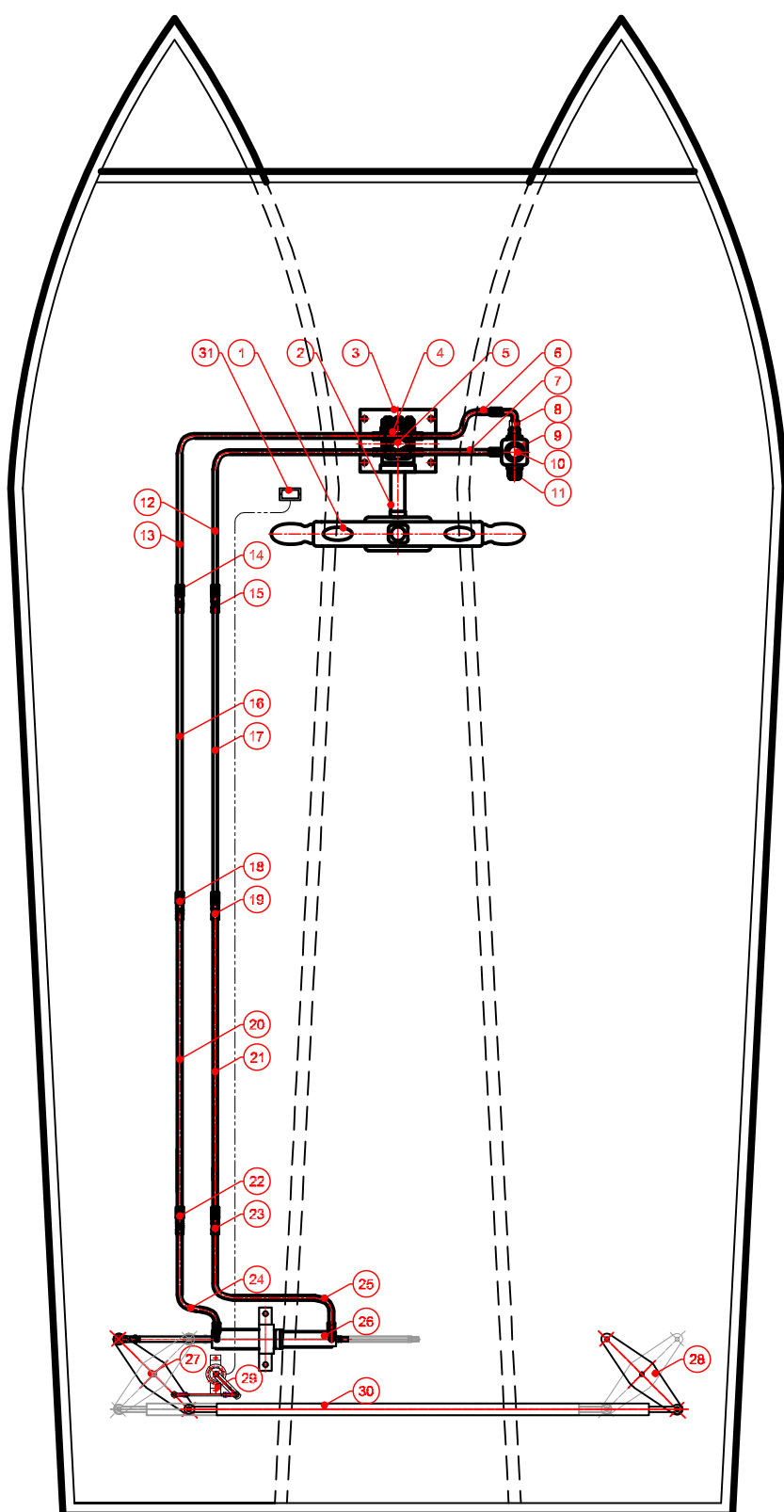

SPECIFICATIONS

1. Tiller Arm Radius	: 220 mm
2. Pump Capacity:- Manual	: 50 cc/rev
3. Hyd.Actuator:- Model Ram Stroke Bore	: CETO IRS : 20mm. : 260mm. : 40mm.
4. Pipe:- Material OD ID	: EN-10305-4 : 12mm. : 8mm.
5. Hose:- Grade ID	: R1 : 3/8"
6. Test pressure Operating pressure	: 90 bar : 40bar
7. Steering Wheel Dia	: 24" (600 mm)

LEGENDS:

1. Steering Wheel
2. Steering Column
3. Vertical Bracket
4. Hyd.Banjo Conn.16x1/2"
5. Helm Pump
6. Hose -1
7. Hose - 2
8. Male Stud 16 x 1/2"
9. Oil Reservoir
10. Filler Breather
11. Oil Level Gauge
12. Hose - 3
13. Hose - 4
14. Std. Coupling 16mm.
15. Std. Coupling 16mm.
16. Seamless Steel Tube
17. Seamless Steel Tube
18. Std. Coupling 16mm.
19. Std. Coupling 16mm.
20. Seamless Steel Tube
21. Seamless Steel Tube
22. Std. Coupling 16mm.
23. Std. Coupling 16mm.
24. Hose - 5
25. Hose - 6
26. Ceto IRS
27. Tiller Arm - 1 (Customer Supply)
28. Tiller Arm - 2 (Customer Supply)
29. Rudder Angle Sensor
30. Connection Rod (Customer Supply)
31. Rudder Angle Indicator



**MAC ♦ N ♦ HOM SYSTEMS
KOCHI - 20**

DESIGNATION

SCHEMATIC DIAGRAM OF TWIN RUDDER
WITH CONNECTION ROD

DWG. No.

MHS-1385A

DATE

16 - 05 - 2022

A

B

C

D

E

F

G

H